



# INSTALLATION INSTRUCTIONS

<b>Accessory</b> <b>AUDIO ATTACHMENT KIT</b> <b>P/N 08B08-MEG-100</b>	<b>Application</b> <b>VT750C</b>	<b>Publications No.</b> <b>MII 11775</b>
		<b>Issue Date</b> <b>October 2006</b>

**Honda Dealer: Please give a copy of these instructions to your customer.**

## PARTS LIST

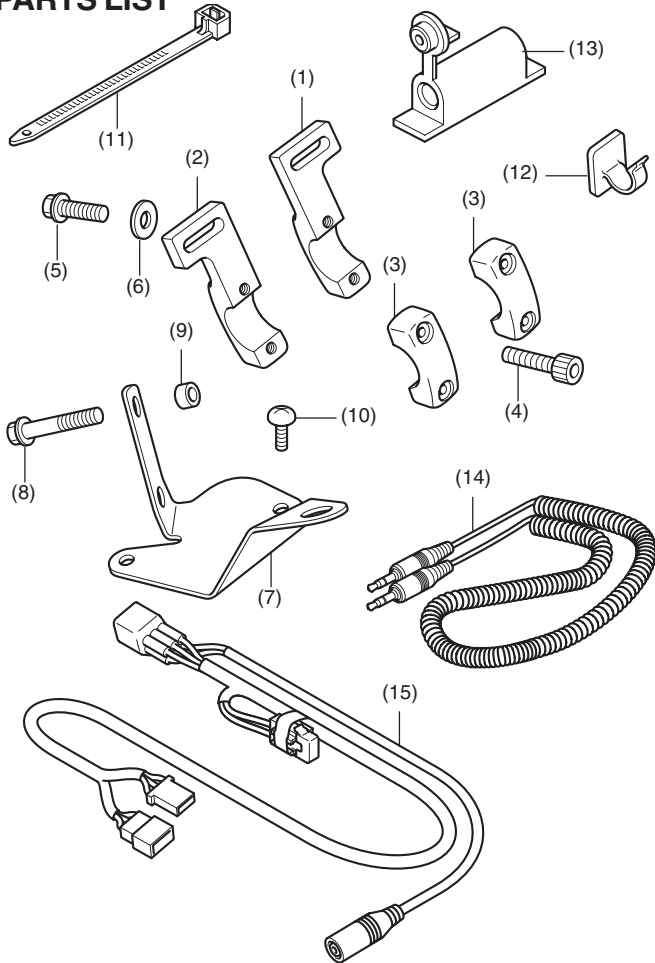

No.	Description	Qty
(1)	Right speaker holder	1
(2)	Left speaker holder	1
(3)	Speaker holder	2
(4)	6 mm socket bolt	4
(5)	6 mm SH flange bolt (short)	2
(6)	Washer	2
(7)	Bracket	1
(8)	6 mm SH flange bolt (long)	2
(9)	Collar	2
(10)	5 mm screw	2
(11)	Wire tie	5
(12)	Clip	3
(13)	Jack holder	1
(14)	Sub cord	1
(15)	Audio harness	1

DIGITAL AUDIO SYSTEM (Sold separately)  
P/N 08A08-9H1-000

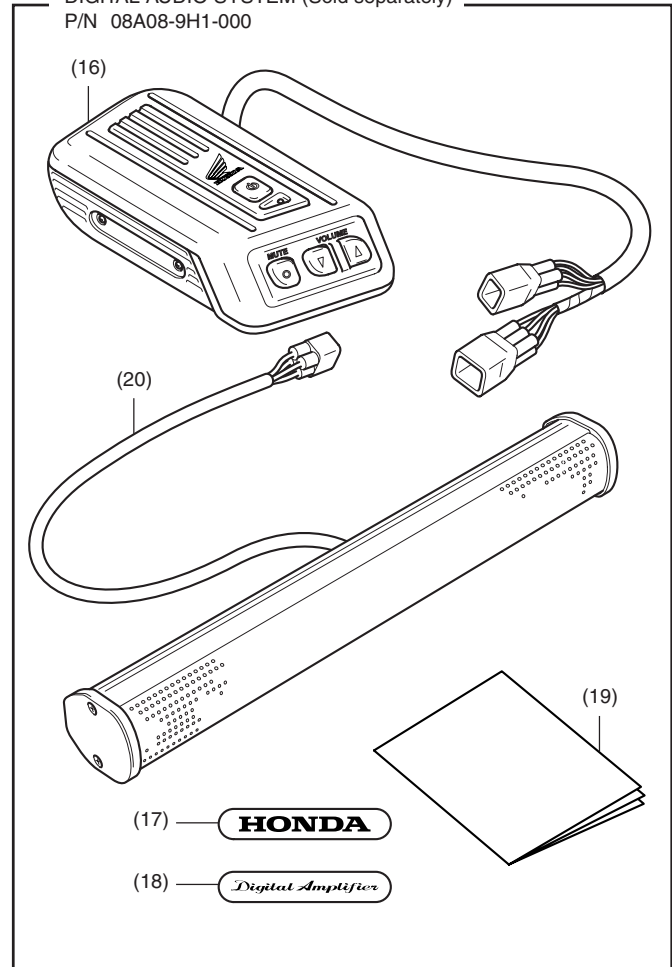

No.	Description	Qty
(16)	Amplifier unit	1
(17)	Honda emblem	1
(18)	Digital amplifier emblem	1
(19)	Owner's Manual	1
(20)	Speaker	1

## TOOLS AND SUPPLIES REQUIRED

Socket (8 mm)  
 Ratchet  
 Hex wrench (5 mm)  
 Phillips® screwdriver  
 Cutting pliers  
 Electrical tape  
 Isopropyl alcohol  
 Shop towel  
 Torque wrench

## TORQUE CHART

Tighten all screws, bolts and nuts to their specified torques. Refer to the Service Manual for the tightening torques of removed parts.

Item	N·m	kgf·m	lbf·ft
5 mm screw	4	0.4	2.9
6 mm SH flange bolt	9	0.9	6.5
6 mm socket bolt	10	1.0	7

## INSTALLATION

### NOTE:

- Disconnect the negative cable from the battery before installing this accessory.
- Trim the excess ends off the wire ties after attaching them to the wire harnesses. Do not allow the cut part of the wire tie to interfere with another harness or brake hose.
- Be sure to observe all safety notes and precautions described in the Service Manual while removing and installing the fuel tank. Gasoline is extremely flammable and is explosive under certain conditions. Refuel in a well-ventilated area with the engine stopped. Do not smoke or allow flames or sparks in the area where gasoline is stored or where the fuel tank is refueled.

1. Refer to the Service Manual to remove the parts.

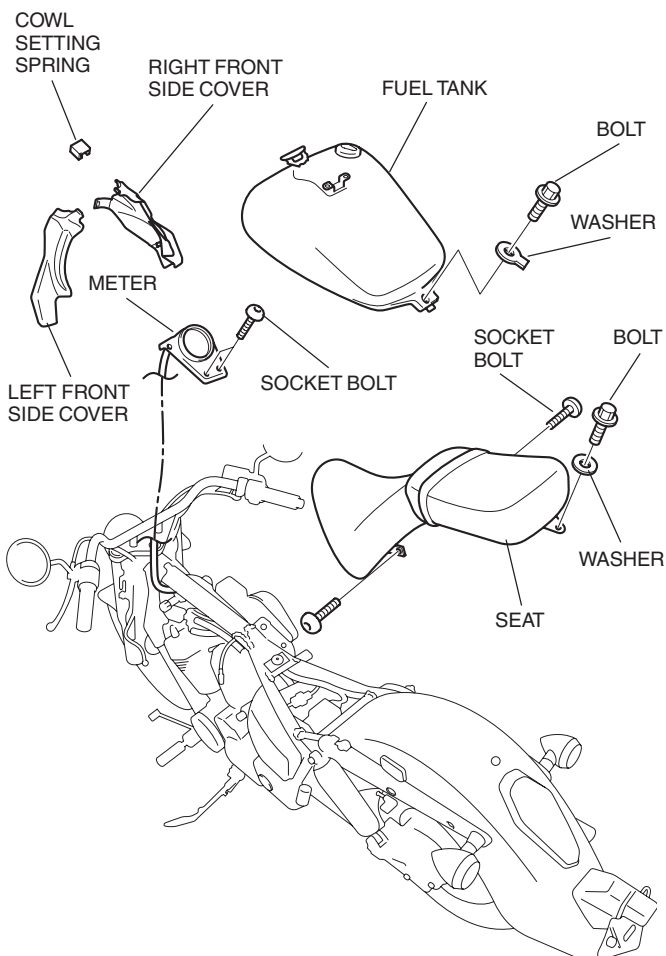

2. Loosely install the speaker holder on the handlebar as shown.

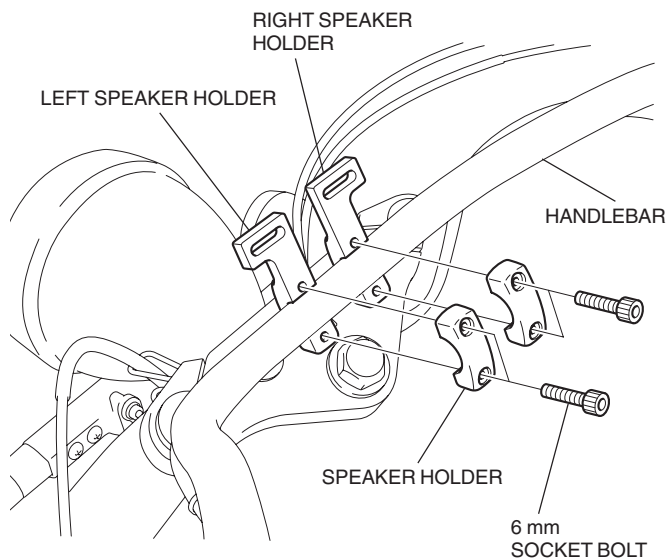

3. Loosely install the speaker as shown.

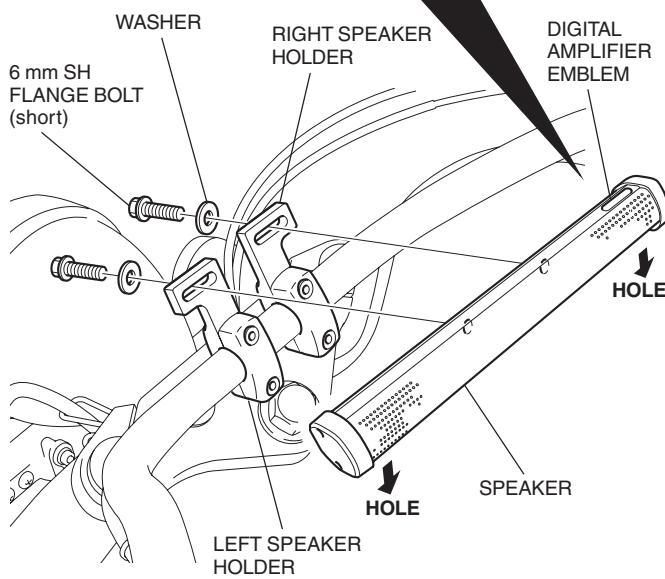
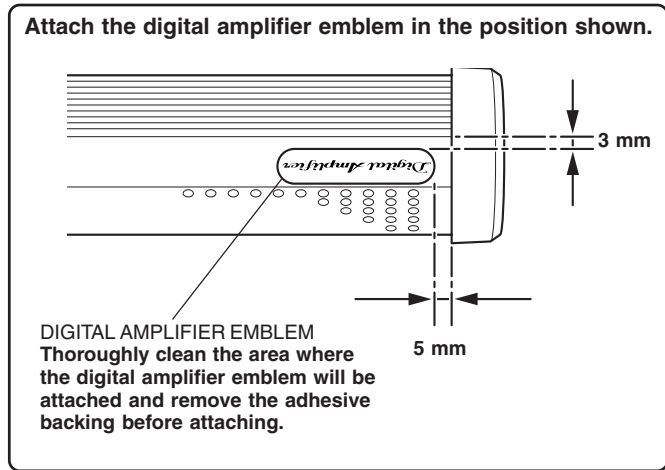

4. Install the bracket on the amplifier unit as shown.

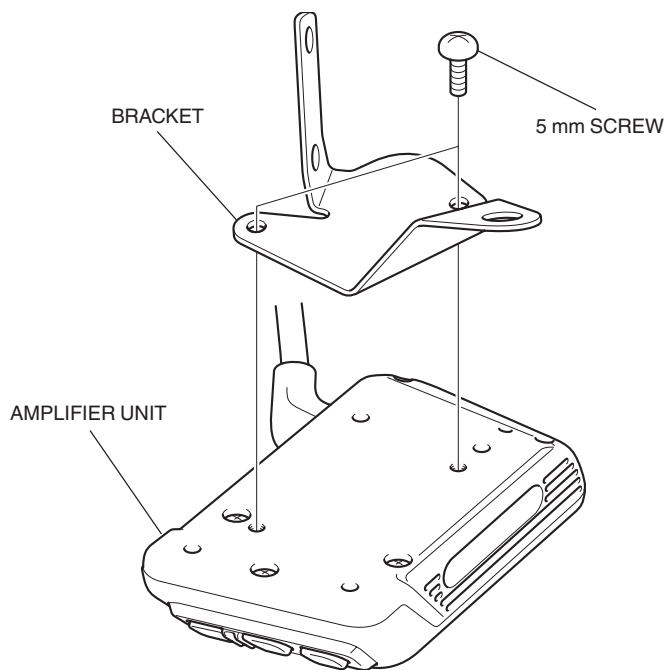

5. Install the amplifier unit as shown.

- Tighten the upper bolt first, then tighten the lower bolt.

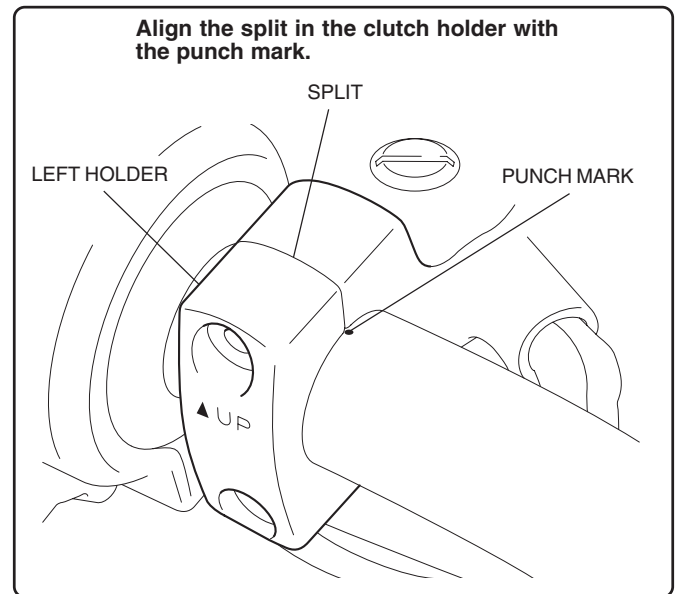
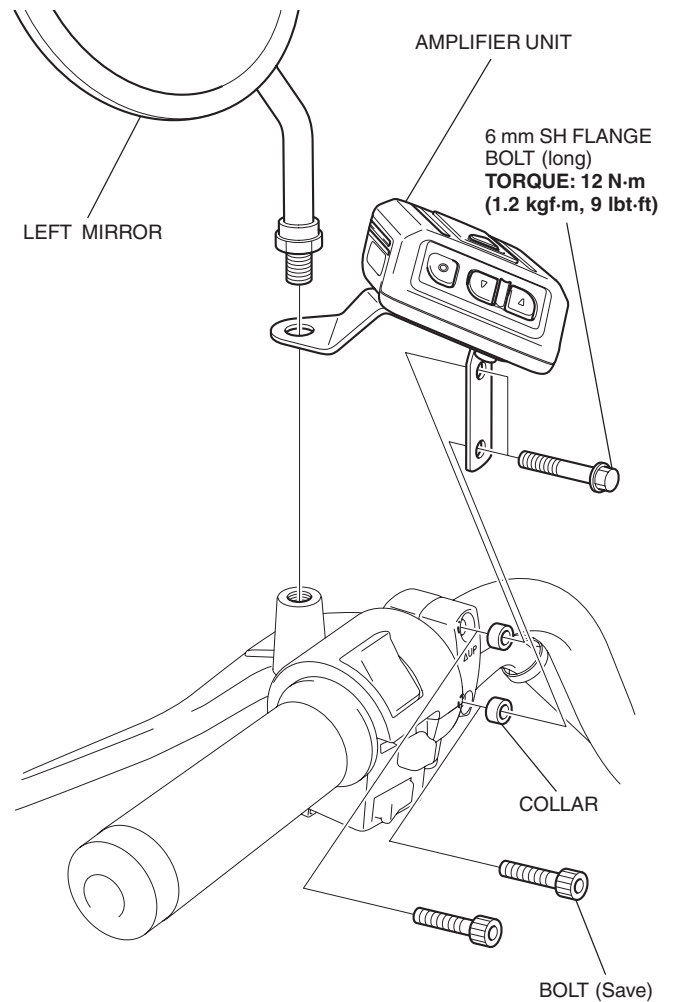

6. Route the amplifier unit harness as shown.

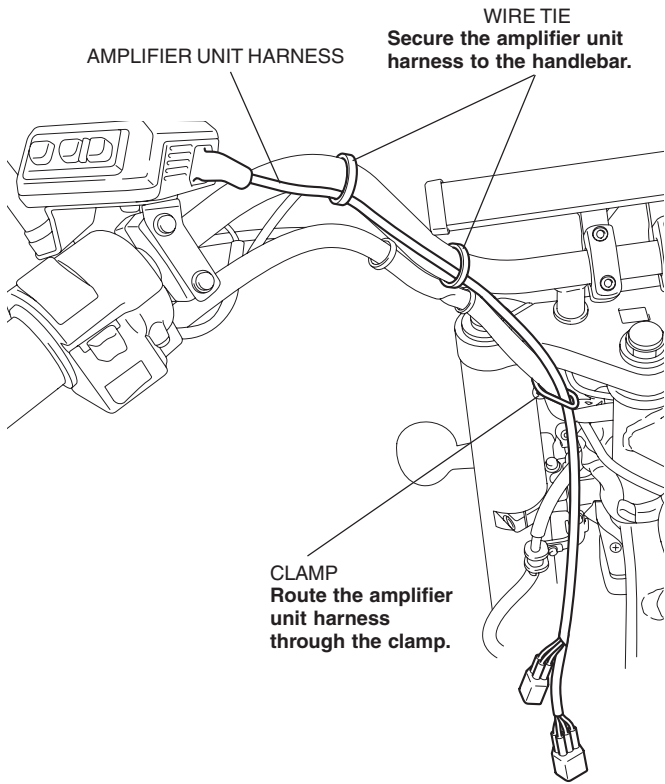

7. Route the harnesses and connect them as shown.

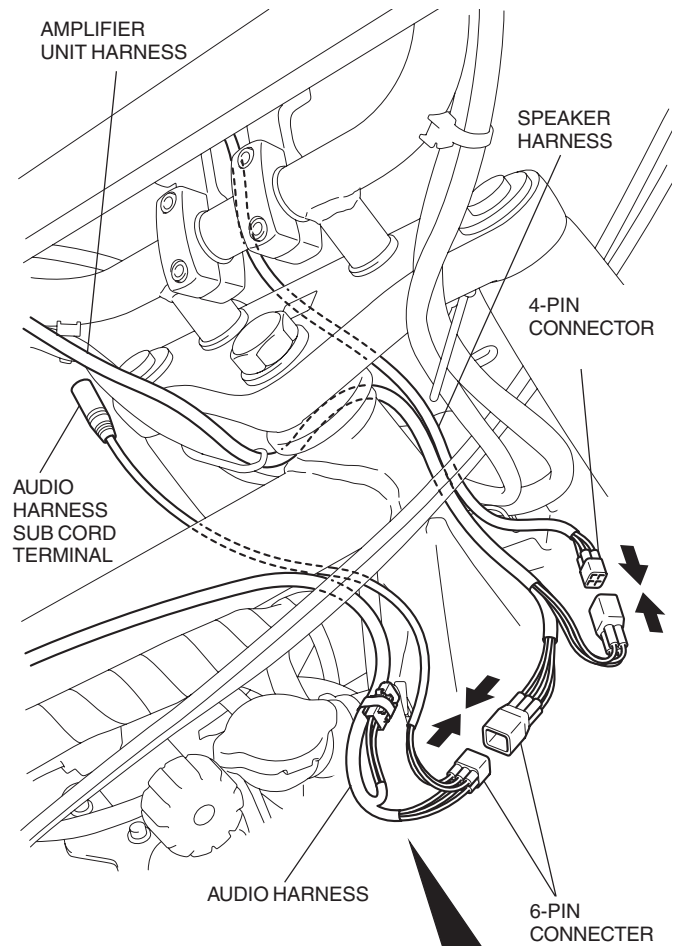

ELECTRICAL TAPE  
Wind the electrical tape onto the fuse.

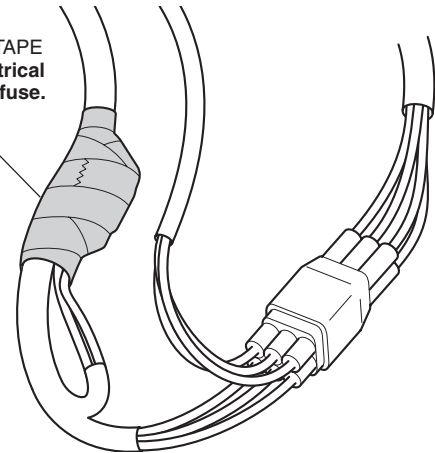

8. Secure the harness using the wire tie as shown.

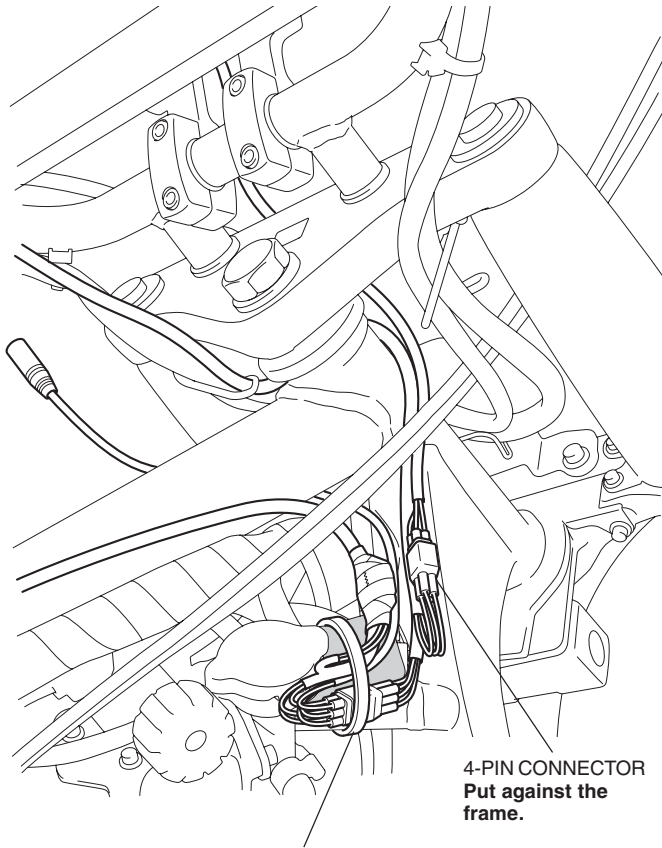

9. Route the audio harness along the motorcycle harness as shown.

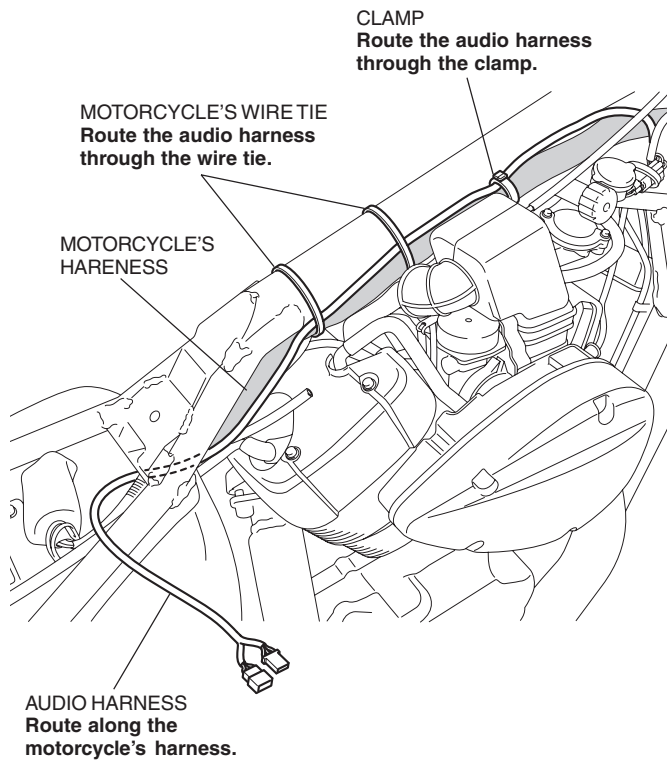

10. Route the audio harness and connect it as shown.

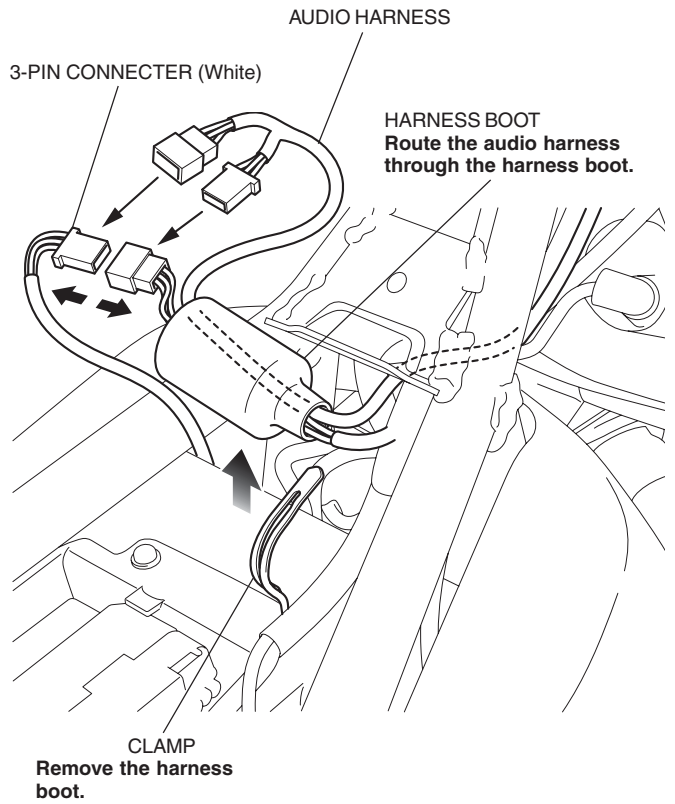

11. Store the connectors in the harness boot.

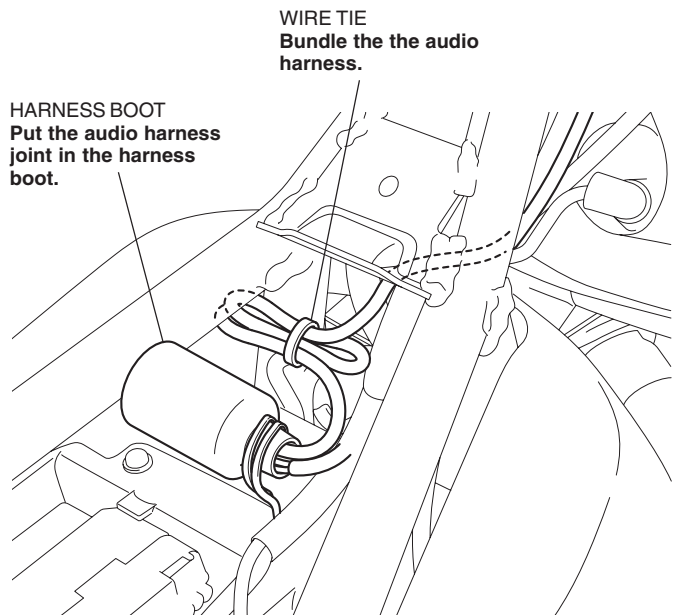

12. Route the audio harness sub cord as shown.

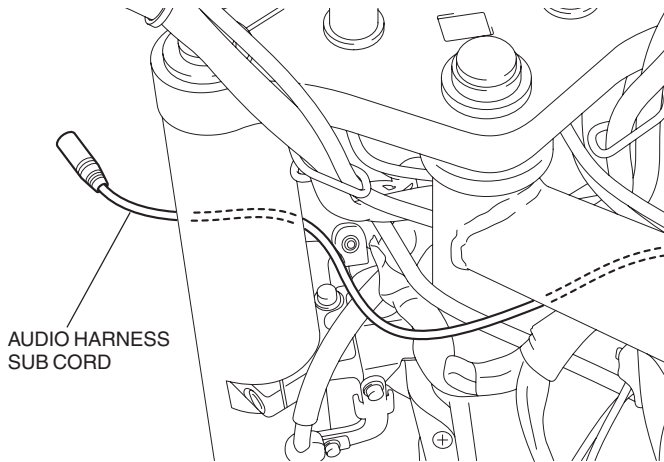

13. Attach the clip to the position shown to secure the harnesses.

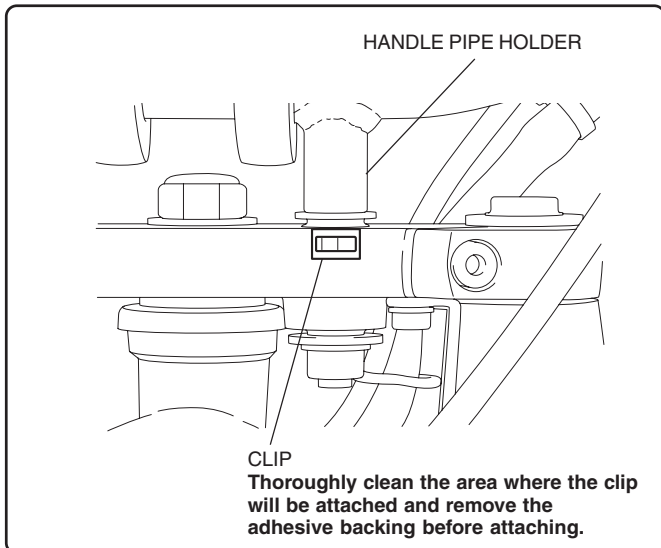
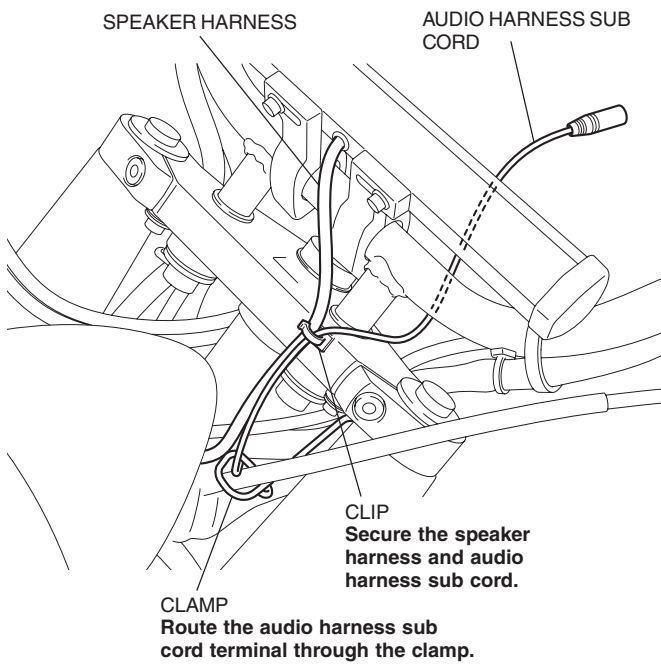

14. Insert the audio harness sub cord terminal into the jack holder as shown.

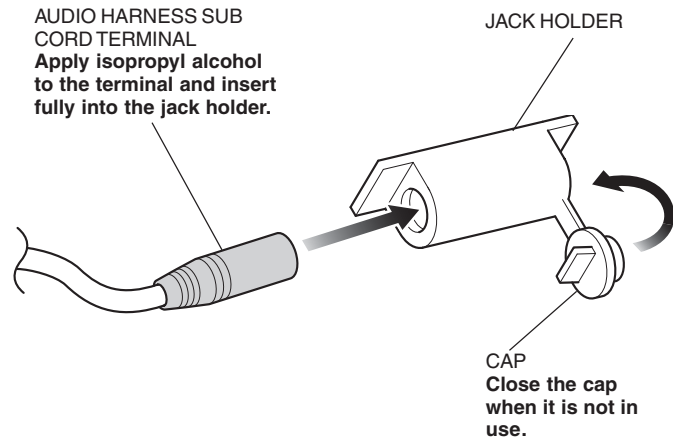

15. Attach the jack holder in the position shown.

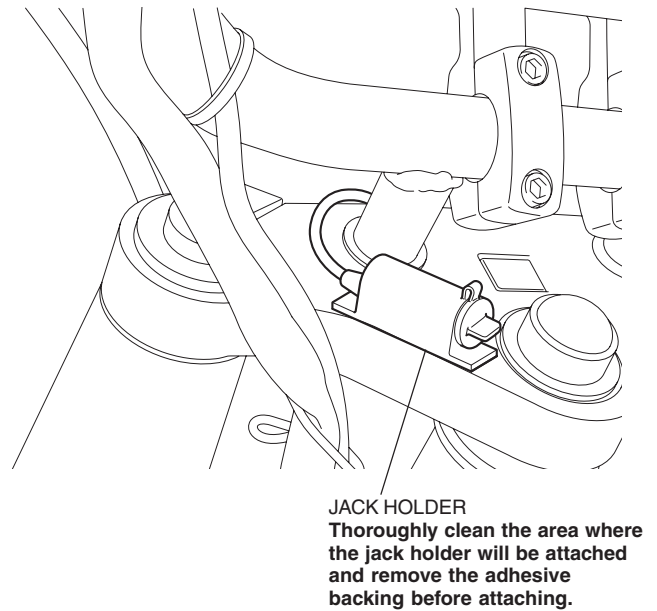

16. Sit on the motorcycle and adjust the speaker so it faces toward you. Tighten the speaker holders securely.

- **Move the handlebar right and left and check that the harnesses are not pinched by any components and that they are not pulled taut.**

**Tighten the upper bolt first, then tighten the lower bolt.**

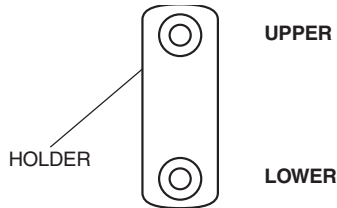

**SPEAKER**  
Align the center of the speaker with the center of the motorcycle and secure it.

**SPEAKER SURFACE**

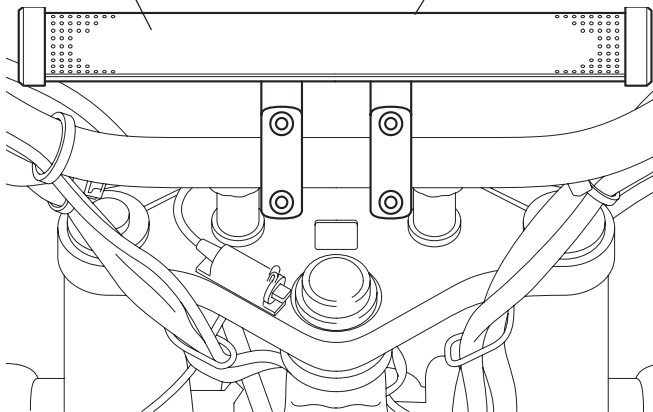

17. Install the removed motorcycle parts in the reverse order of removal.

18. Connect the sub cord as shown when it is used.

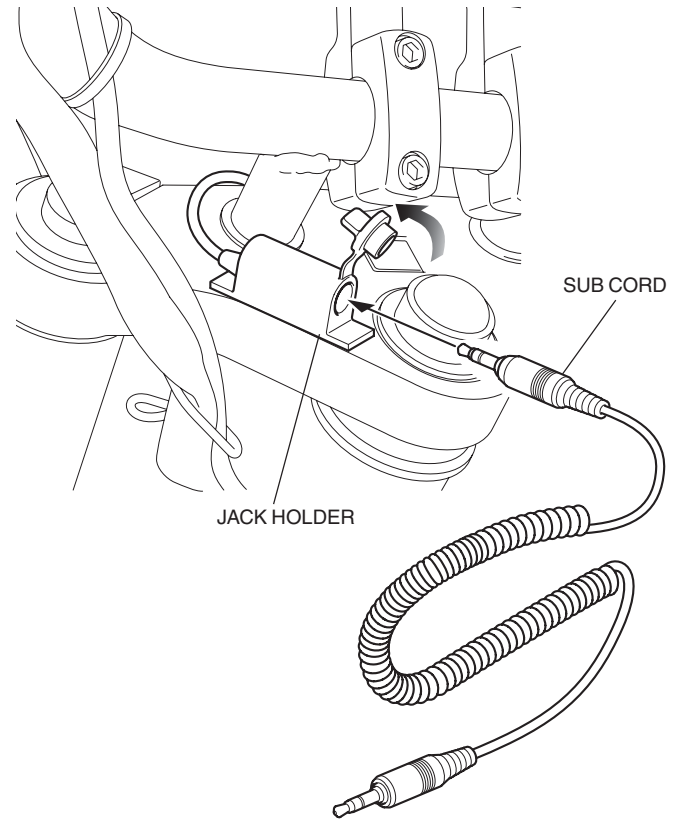

19. Install the clip on the sub cord and install the sub cord on the motorcycle so that it does not interfere with riding the motorcycle.

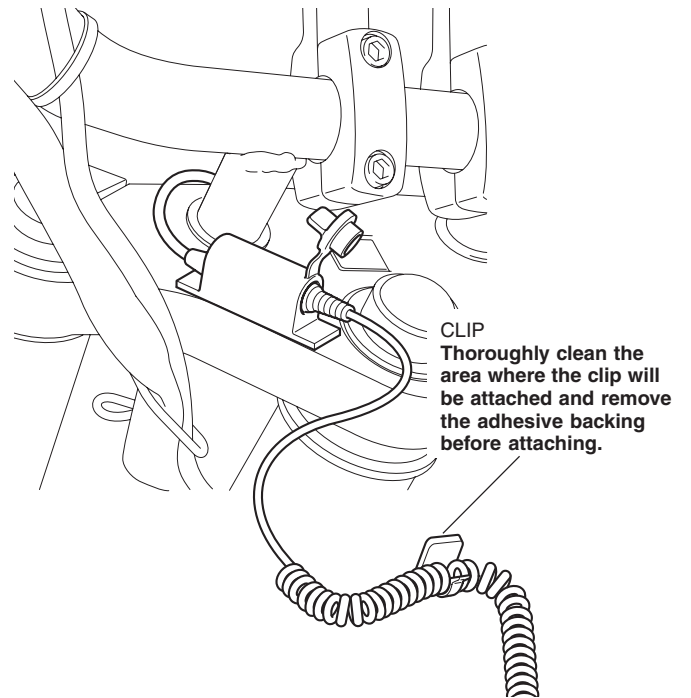

20. Check the controller, speaker, headlight and the other lights for proper operation. Check that the harnesses are not pulled taut.