

HONDA

INSTALLATION INSTRUCTIONS

Accessory

**AUDIO ATTACHMENT KIT
P/N 08B08-MFE-100**

Application

VT750C2

Publications No.

MII 11775

Issue Date

October 2006

Honda Dealer: Please give a copy of these instructions to your customer.

PARTS LIST

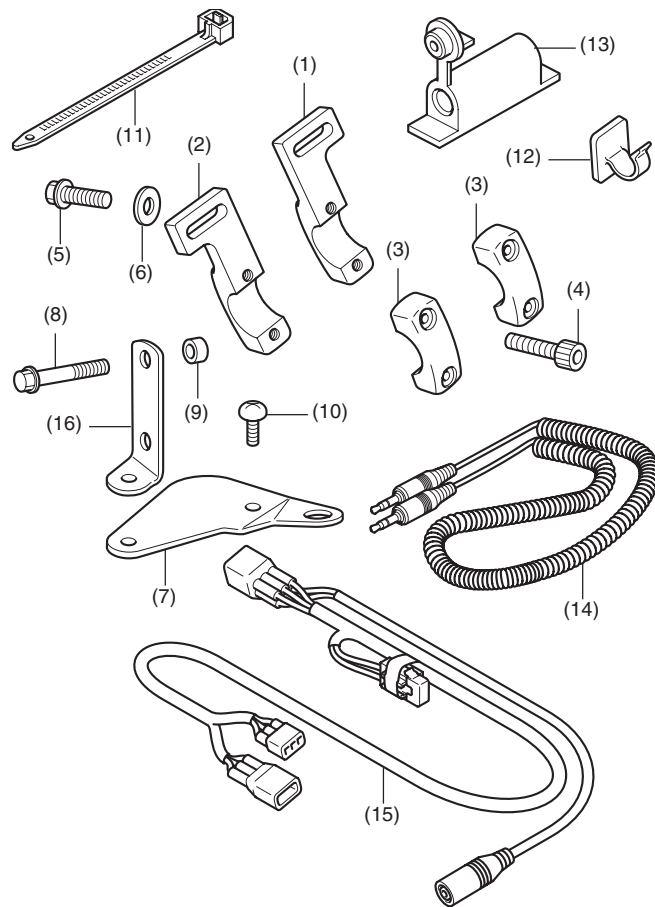

No.	Description	Qty
(1)	Right speaker holder	1
(2)	Left speaker holder	1
(3)	Speaker holder	2
(4)	6 mm socket bolt	4
(5)	6 mm SH flange bolt (short)	2
(6)	Washer	2
(7)	Bracket	1
(8)	6 mm SH flange bolt (long)	2
(9)	Collar	2
(10)	5 mm screw	2
(11)	Wire tie	5
(12)	Clip	3
(13)	Jack holder	1
(14)	Sub cord	1
(15)	Audio harness	1
(16)	Sub bracket	1

DIGITAL AUDIO SYSTEM (Sold separately)
P/N 08A08-9H1-000

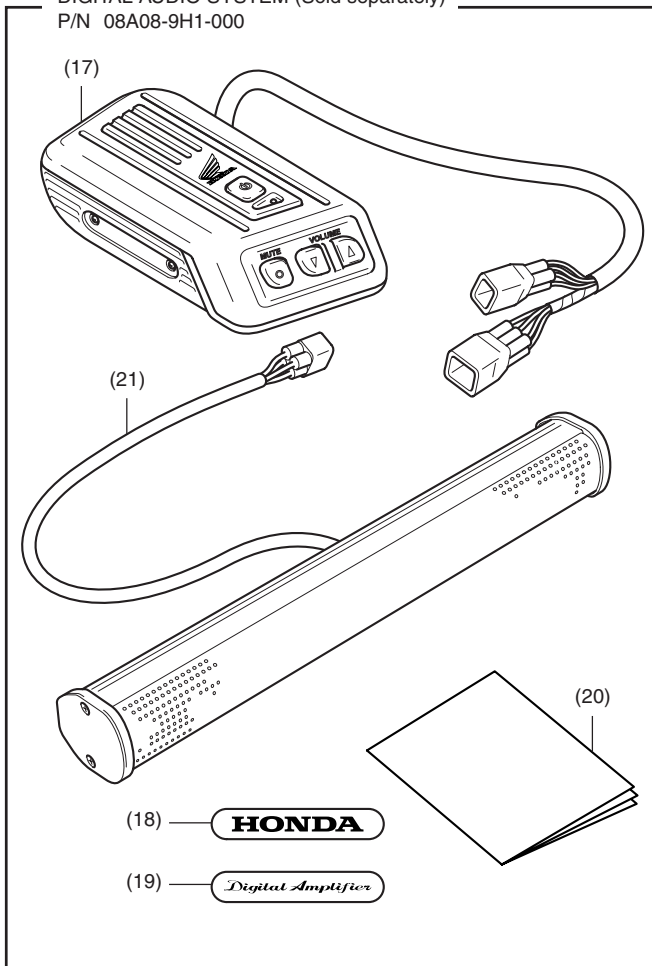

No.	Description	Qty
(17)	Amplifier unit	1
(18)	Honda emblem	1
(19)	Digital amplifier emblem	1
(20)	Owner's Manual	1
(21)	Speaker	1

TOOLS AND SUPPLIES REQUIRED

Socket (8 mm)
 Ratchet
 Hex wrench (5 mm)
 Phillips® screwdriver
 Electrical tape
 Cutting pliers
 Isopropyl alcohol
 Shop towel
 Torque wrench

TORQUE CHART

Tighten all screws, bolts and nuts to their specified torques. Refer to the Service Manual for the tightening torques of removed parts.

Item	N-m	kgf-m	lbf-ft
5 mm screw	4	0.4	2.9
6 mm SH flange bolt	9	0.9	6.5
6 mm socket bolt	10	1.0	7

INSTALLATION

NOTE:

- Disconnect the negative cable from the battery before installing this accessory.
- The memories of the tripmeter will be erased when you disconnect the battery.
- Trim the excess ends off the wire ties after attaching them to the wire harnesses. Do not allow the cut part of the wire tie to interfere with another harness or brake hose.
- Be sure to observe all safety notes and precautions described in the Service Manual removing and installing the fuel tank. Gasoline is extremely flammable and is explosive under certain conditions. Refuel in a well-ventilated area with the engine stopped. Do not smoke or allow flames or sparks in the area where gasoline is stored or where the fuel tank is refueled.

1. Refer to the Service Manual to remove the parts.

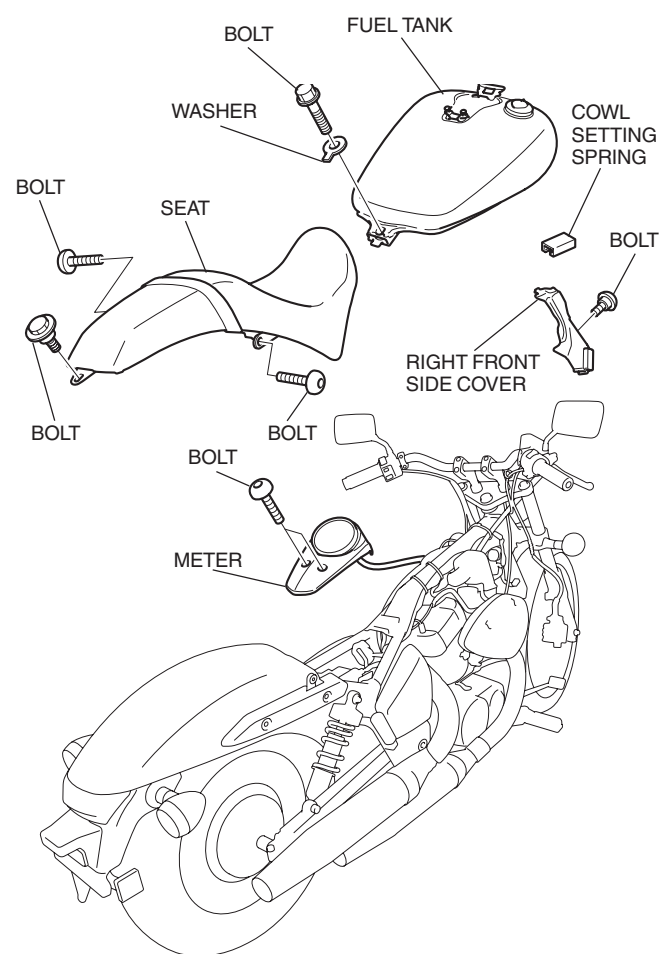

2. Loosely install the speaker holder on the handlebar as shown.

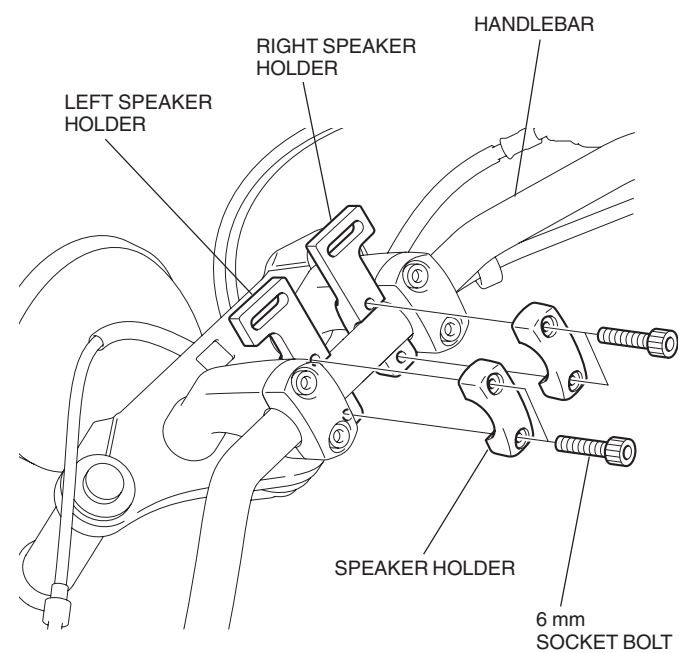

3. Loosely install the speaker as shown.

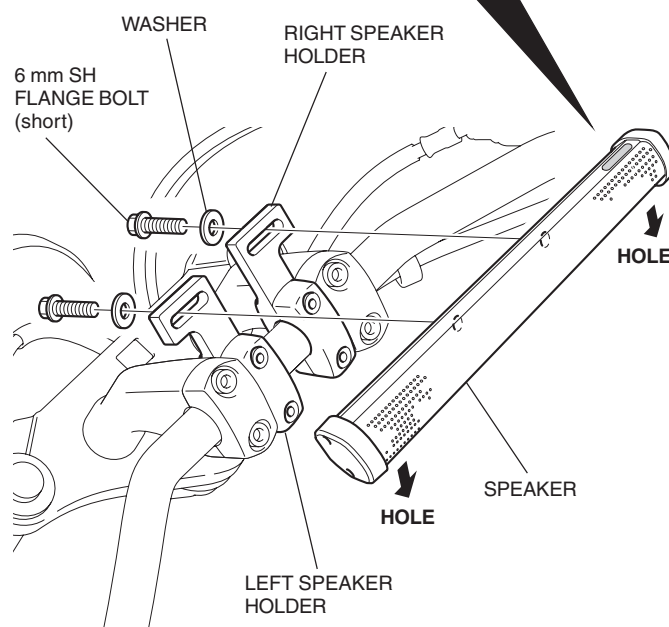
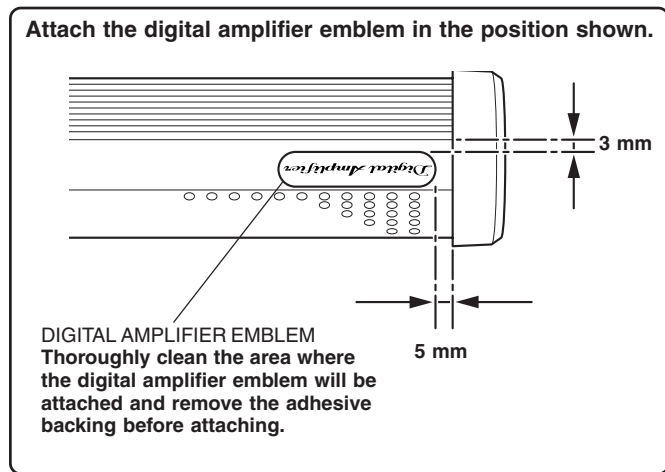

4. Install the bracket on the amplifier unit as shown.

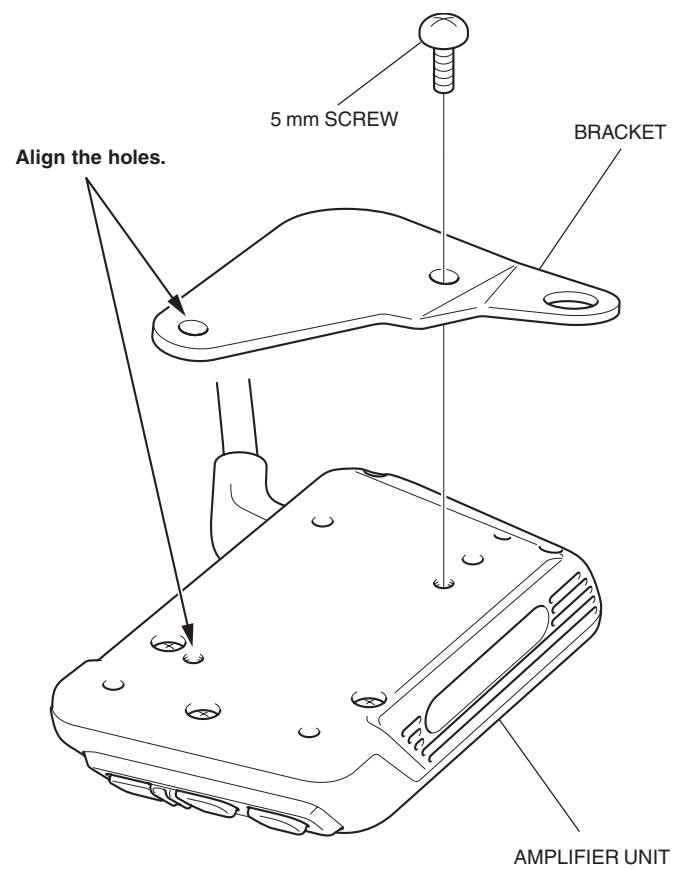

5. Loosely install the amplifier unit as shown.

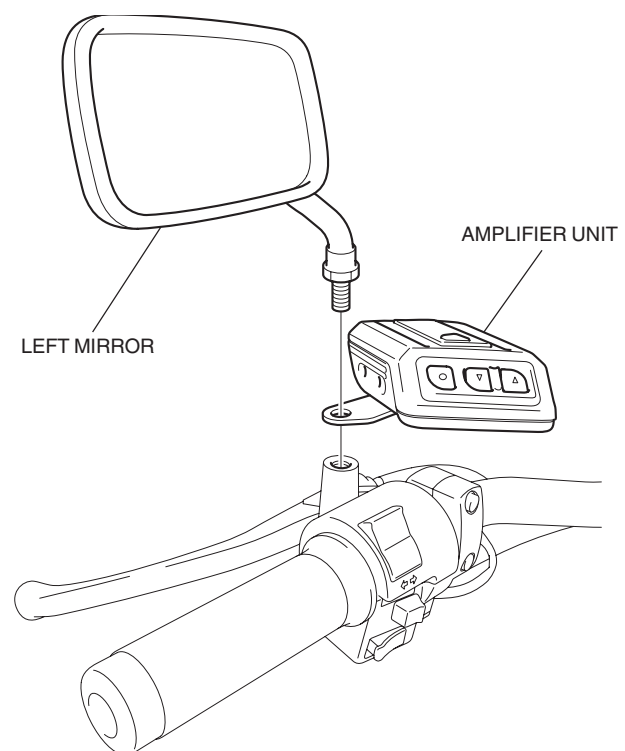

6. Install the amplifier unit as shown.
- Tighten the upper bolt first, then tighten the lower bolt.

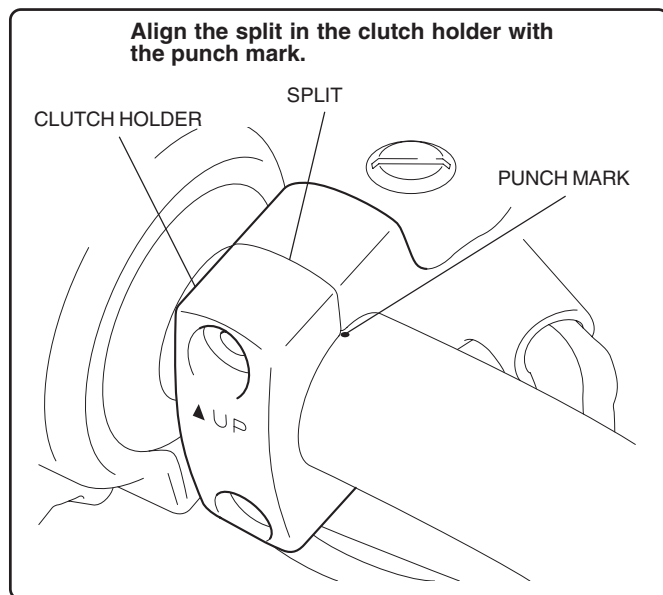
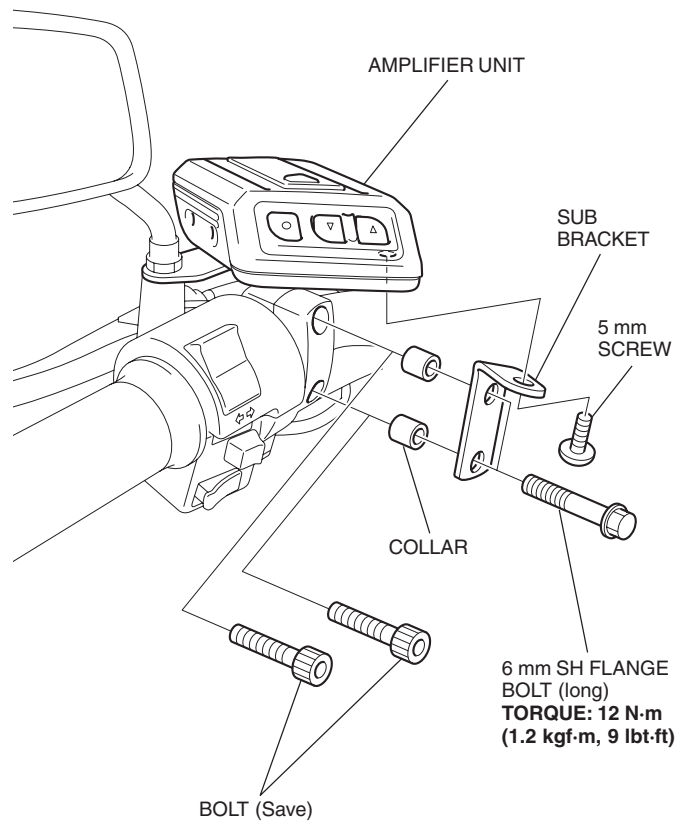

7. Route the amplifier unit harness as shown.

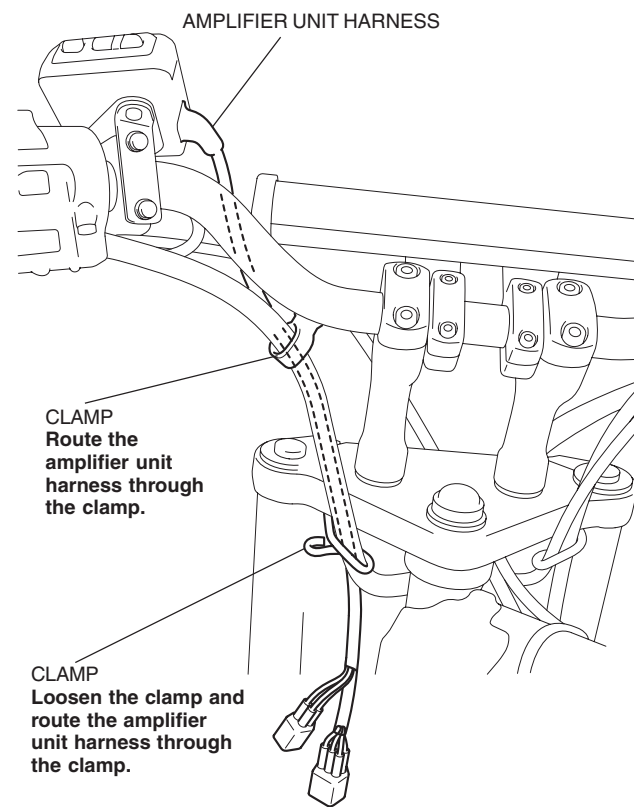

8. Route the audio harness sub cord as shown.

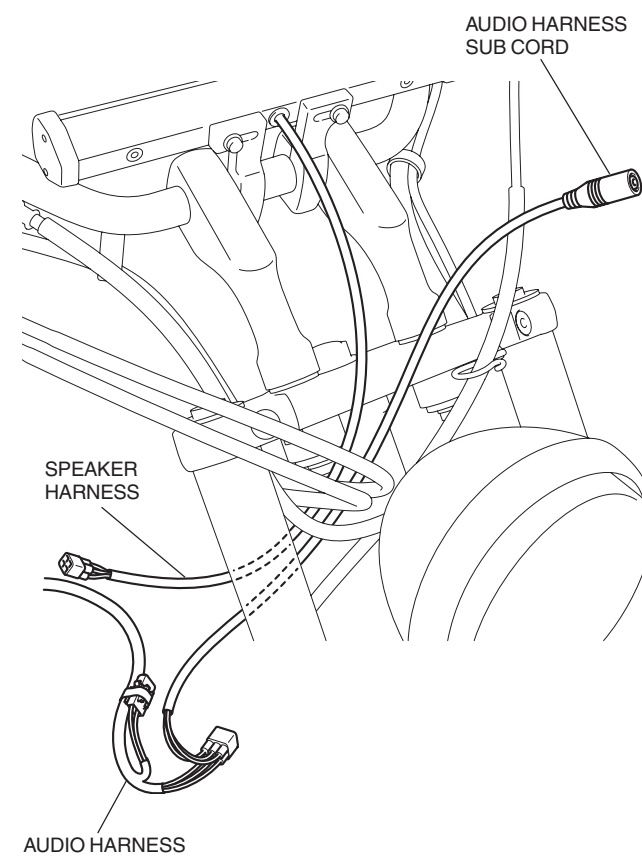

9. Attach the clip to the position shown to secure the harnesses.

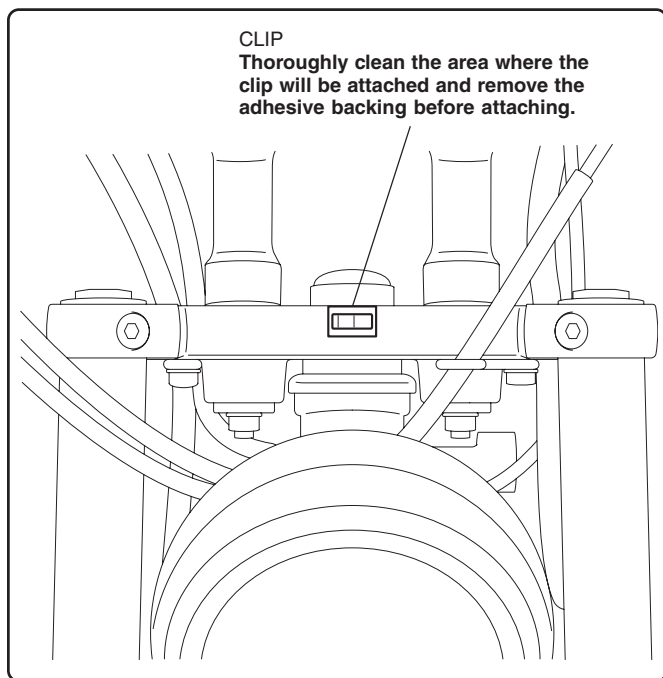
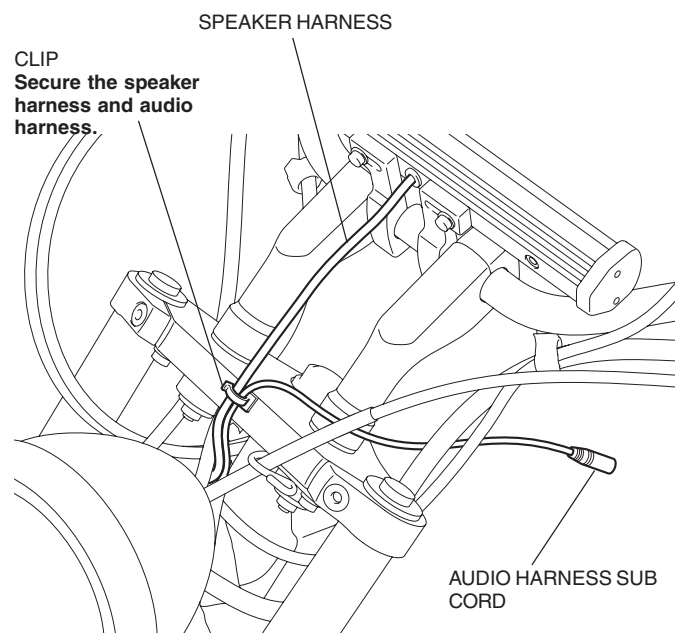

10. Insert the audio harness sub cord terminal into the jack holder as shown.

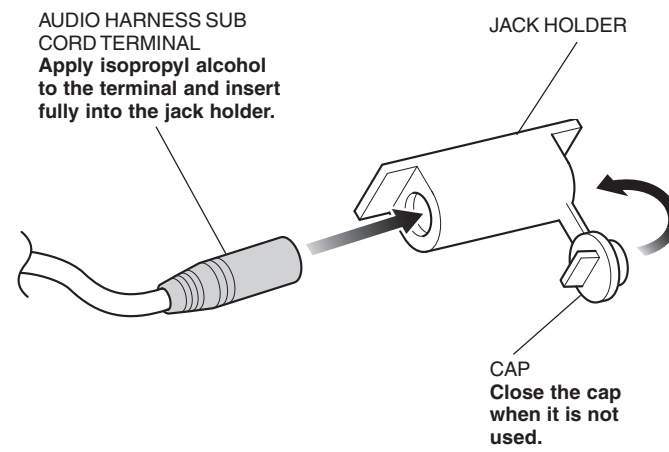

11. Attach the jack holder in the position shown.

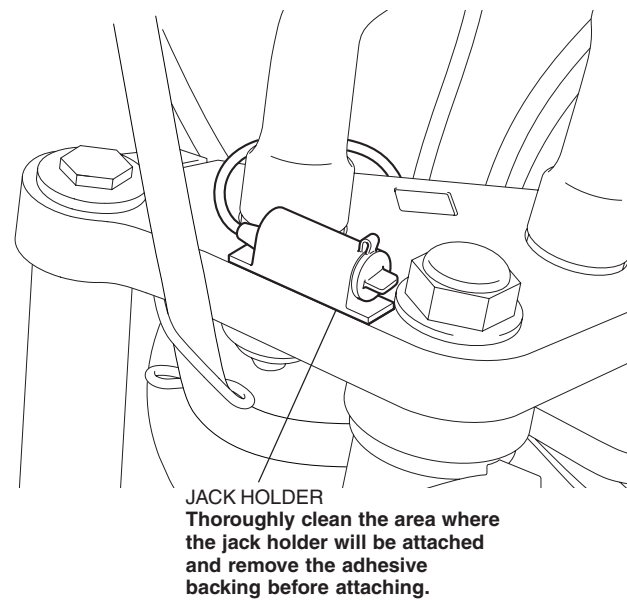

12. Route the harnesses and connect them as shown.

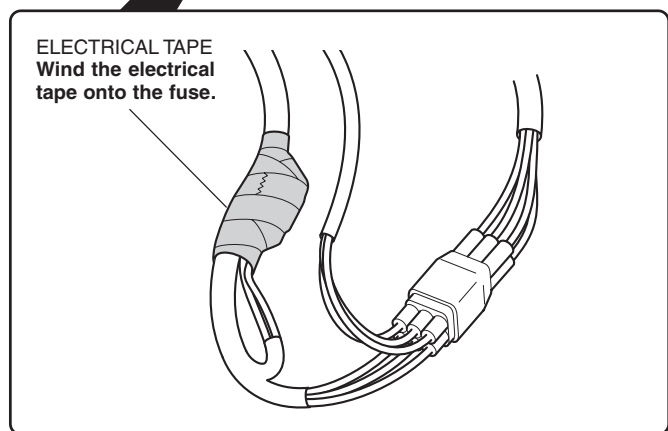
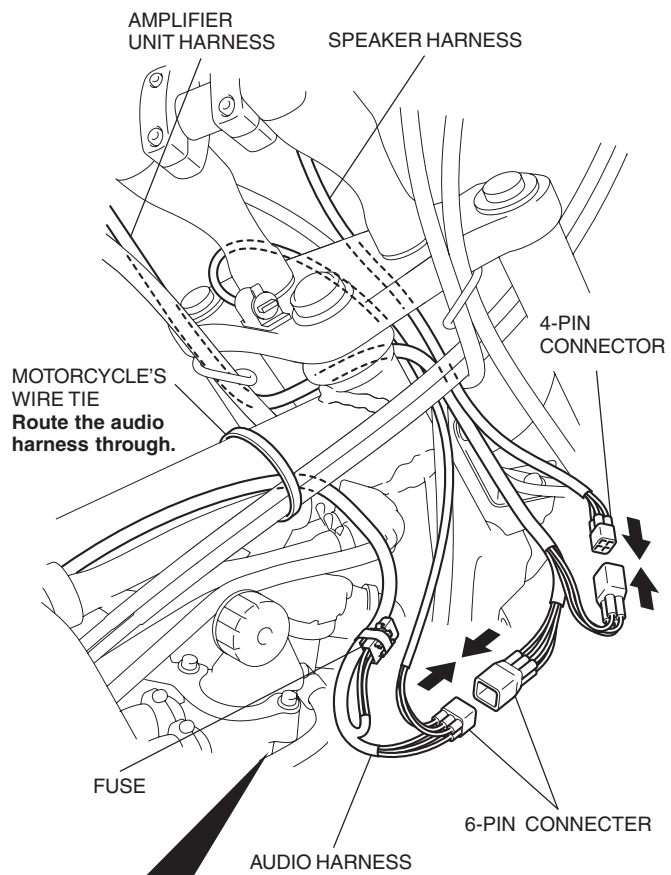

13. Secure the harness using the wire tie as shown.

- Move the handlebar right and left and check that the harnesses are not pinched by components and that they are not pulled taut.

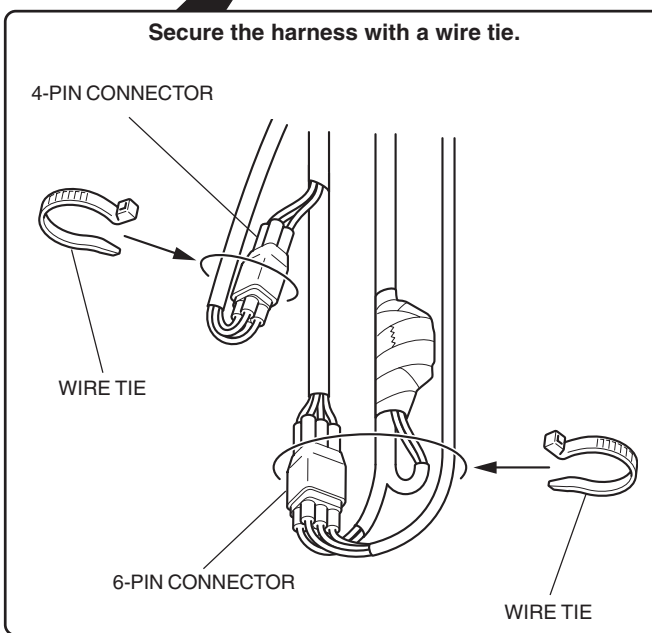
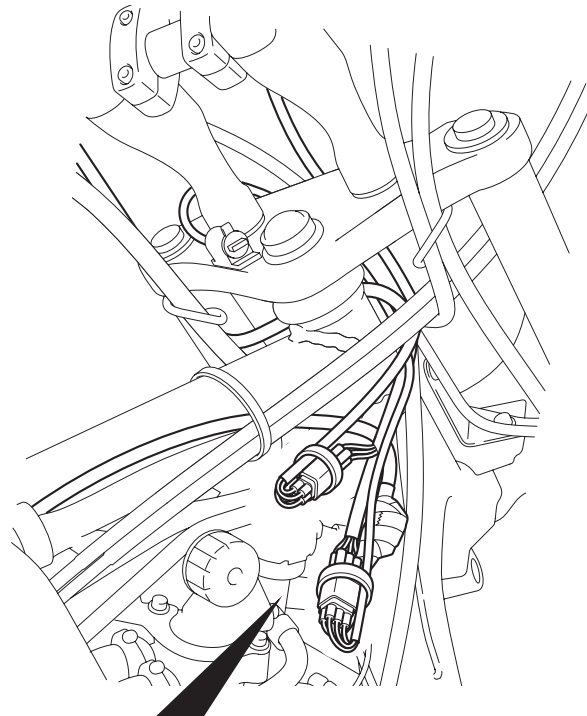

14. Route the audio harness along the motorcycle harness as shown.

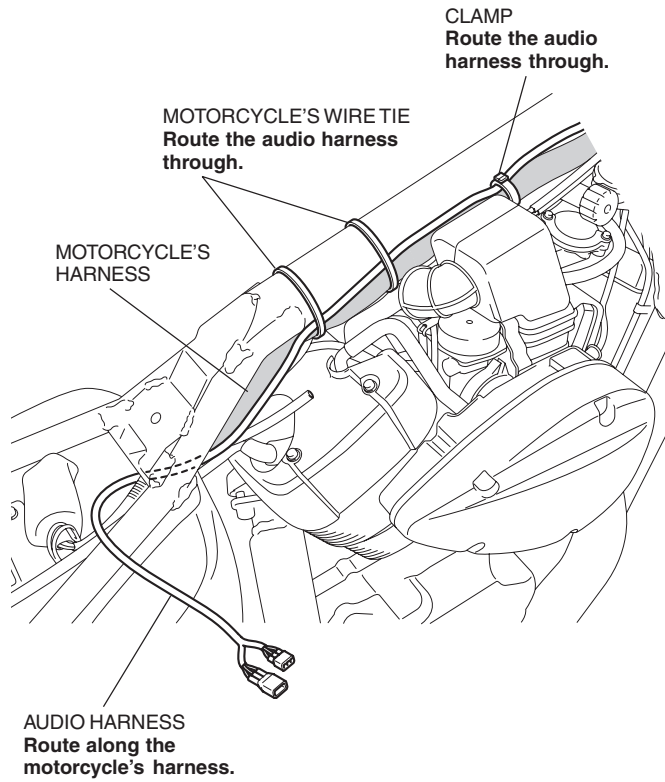

15. Route the audio harness and connect it as shown.

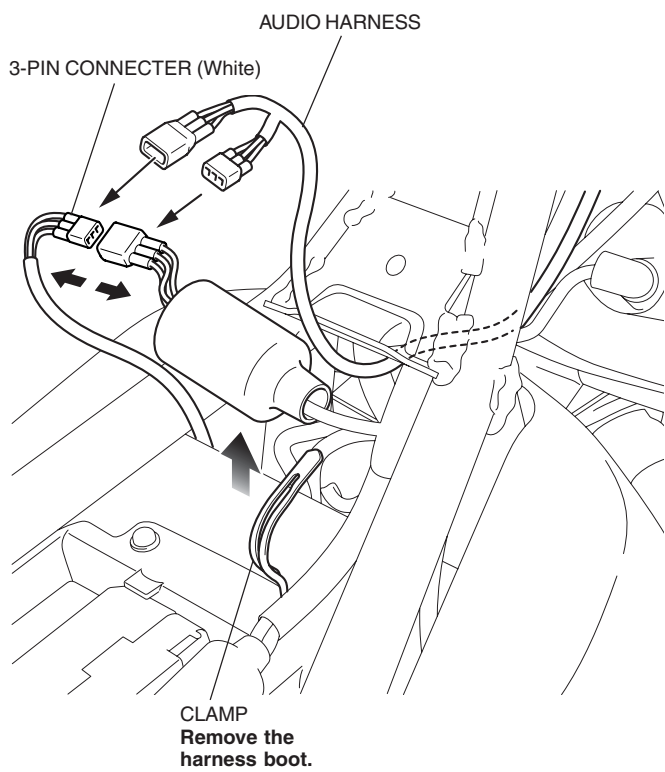

16. Store the connectors in the harness boot.

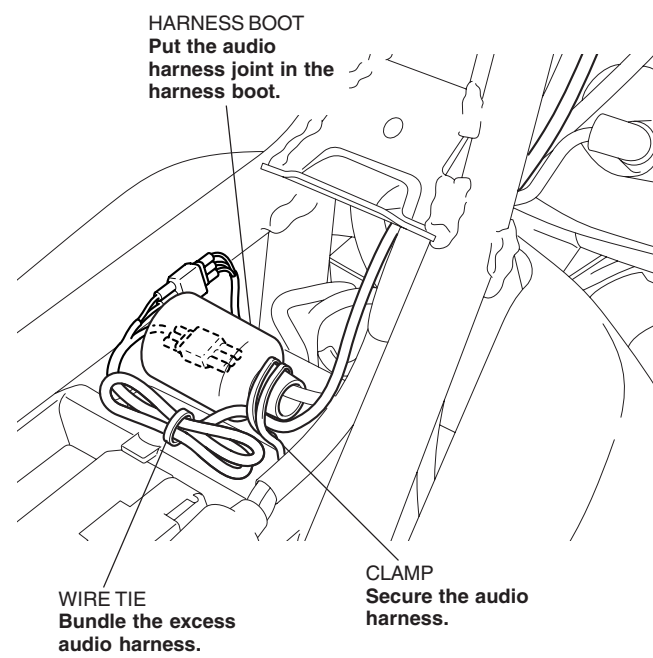

17. Sit on the motorcycle and adjust the speaker so it faces toward you. Tighten the speaker holders securely.

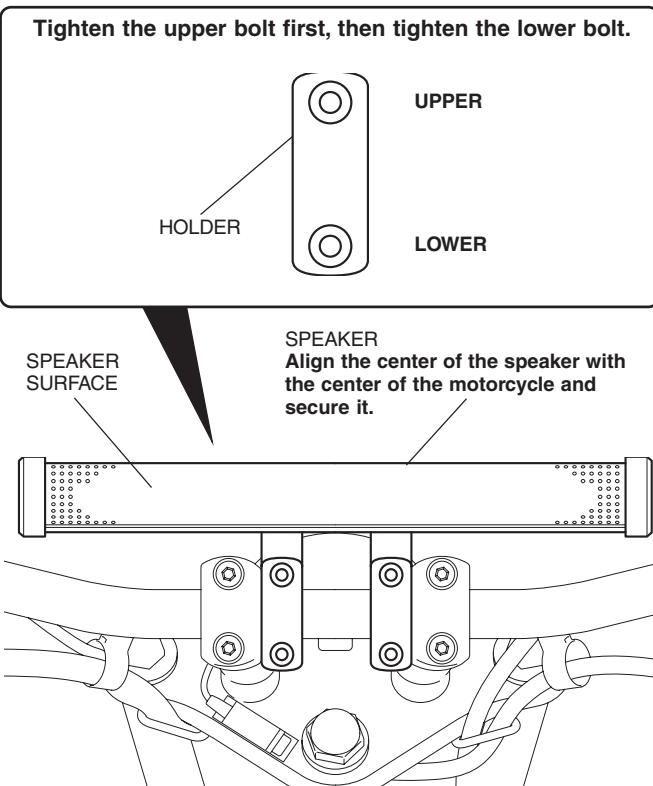

18. Install the motorcycle's removed parts in the reverse order of removal.

19. Connect the sub cord as shown when it is used.

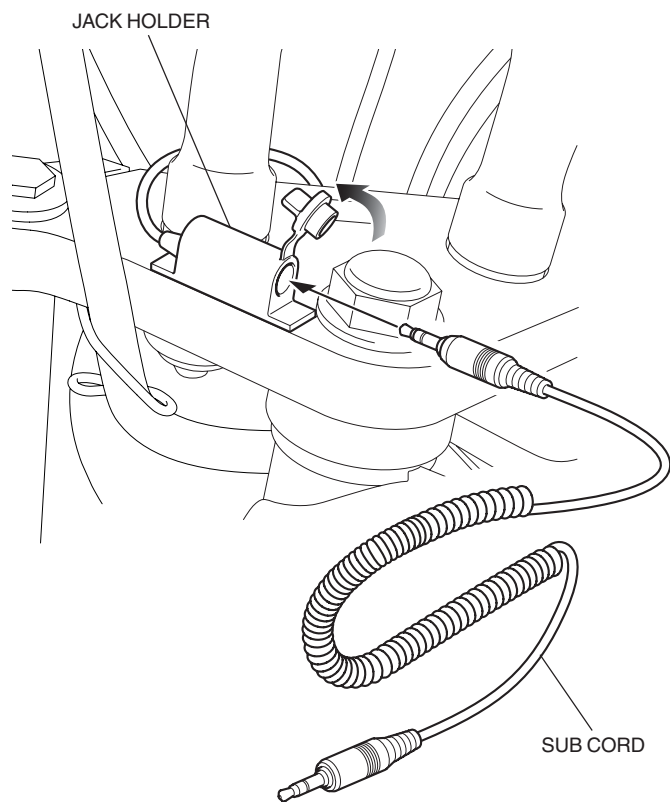

20. Install the clip on the sub cord and attach the clip on the motorcycle in a way that it does not interfere with riding the motorcycle.

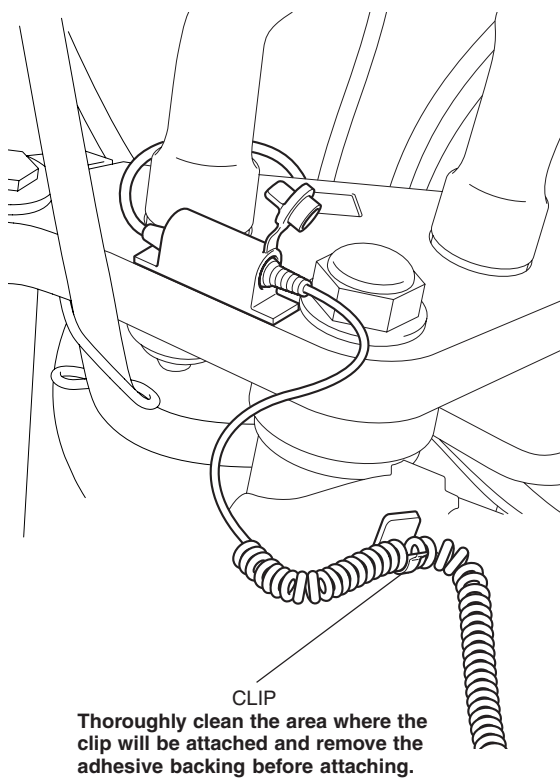

21. Check the controller, speaker, headlight and the other lights for proper operation. Check that the harnesses are not pulled taut.