



# INSTALLATION INSTRUCTIONS

Accessory  
**CHROME LICENSE PLATE FRAME**  
P/N 08P26-MCA-100

Application  
**GL1800**

Publications No.  
**MII 11185**  
Issue Date  
**July 2005**

**Honda Dealer: Please give a copy of these instructions to your customer.**

## PARTS LIST

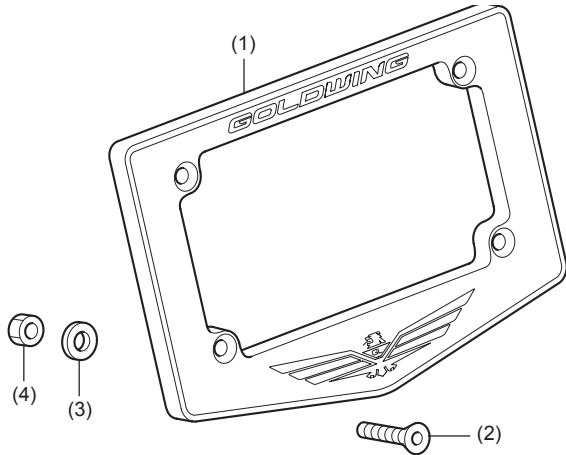

No.	Description	Qty
(1)	Chrome license plate frame	1
(2)	5 mm socket screw	4
(3)	Washer	4
(4)	5 mm lock nut	4

## TOOLS AND SUPPLIES REQUIRED

Box-end wrench (8 mm)  
Hex wrench (3 mm)  
Electric drill motor  
Drill bit, 5 mm (#9)  
Wood block  
Marker  
Torque wrench

## TORQUE CHART

Tighten all screws, bolts and nuts to their specified torques. Refer to the Service Manual for the tightening torques of removed parts.

Item	Nm	kgf-m	lbf-ft
5 mm socket screw	4	0.4	2.9

## INSTALLATION

1. Remove the license plate.

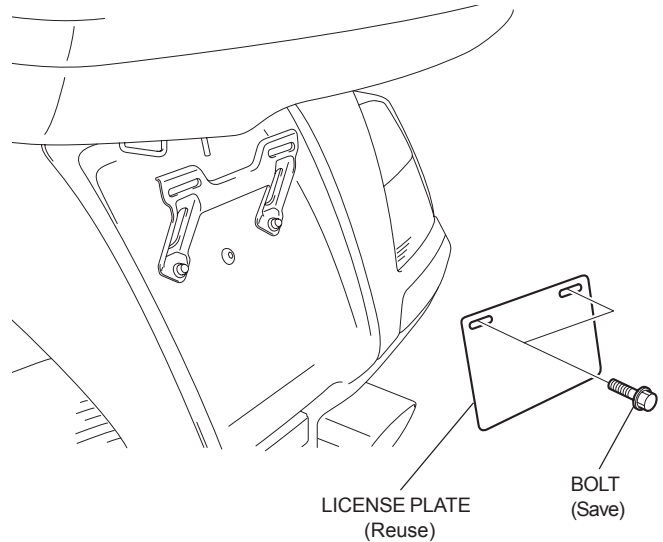

2. Position the license plate in the chrome license plate frame.

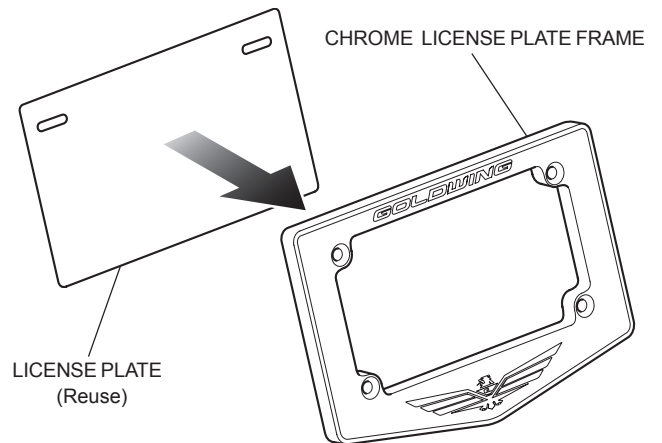

- Using a marker, mark the license plate at each of the two lower holes in the chrome license plate frame as shown. Remove the license plate.

Align each hole in the license plate with each hole in the chrome license plate frame.

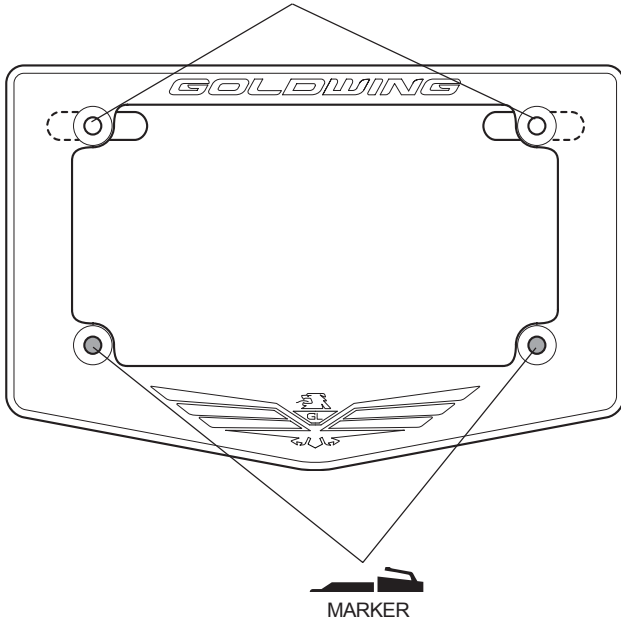

- Wearing eye protection, drill a 5mm (#9) hole through each mark on the license plate.

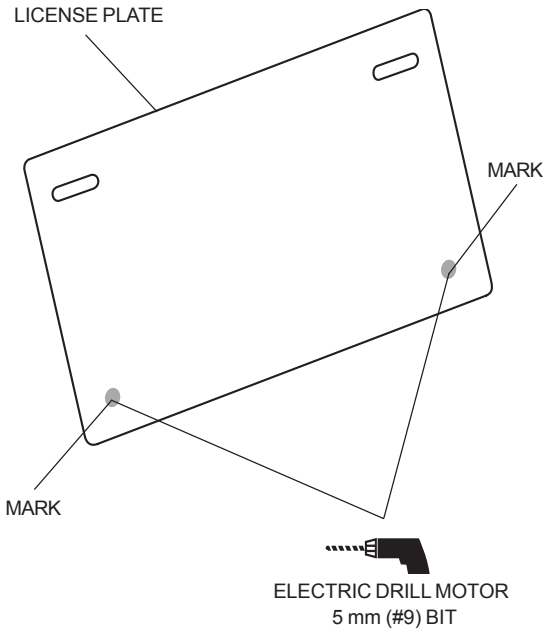

- Install the license plate and chrome license plate frame as shown.

